

DETAIL A
SCALE 6 : 1

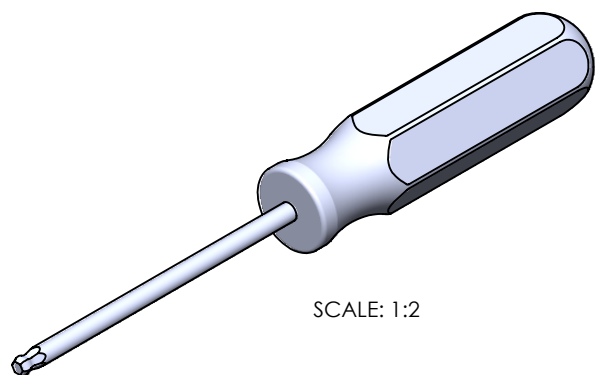
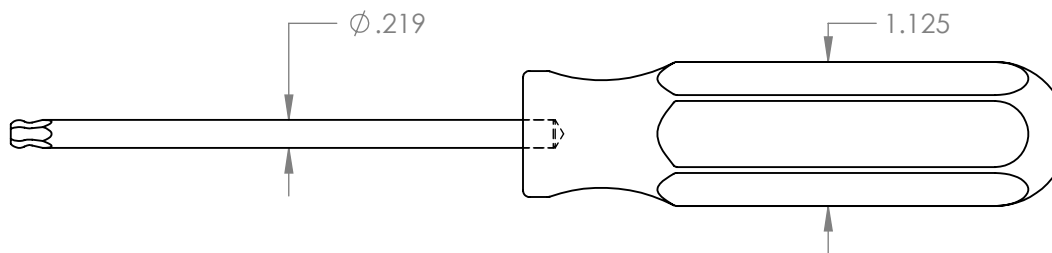
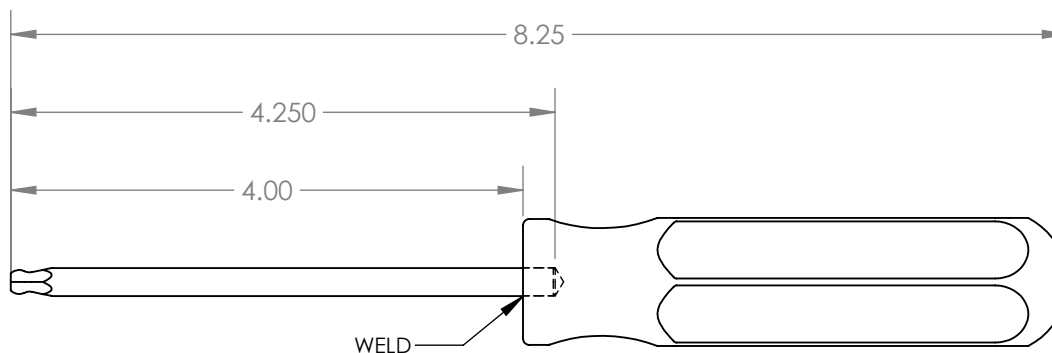

SCALE: 1:2

UNLESS OTHERWISE SPECIFIED: DIMENSIONS ARE IN INCHES			TOLERANCES: X.XX= ±0.13 X.XXX= ±0.015 X.XXXX= -0.0015		
DRAWN	NAME	SIGN	DATE		
APP'VD	A.T.		04.24.19		TITLE: 3/16" BALL DRIVER with STAINLESS STEEL HANDLE
MATERIAL: SHAFT: 465 MAGNETIC S.S. HANDLE: 316 NON-MAGNETIC S.S.					PART NO. 21877
<i>THIS DRAWING IS THE PROPERTY OF STERITOOL, INC. ANY REPRODUCTIONS OR MODIFICATIONS OF THIS DRAWING OR ITS CONTENTS WITHOUT THE CONSENT OF STERITOOL, INC. IS PROHIBITED.</i>					REV: A
			SCALE: 1:1.5	SHEET 1 OF 1	